

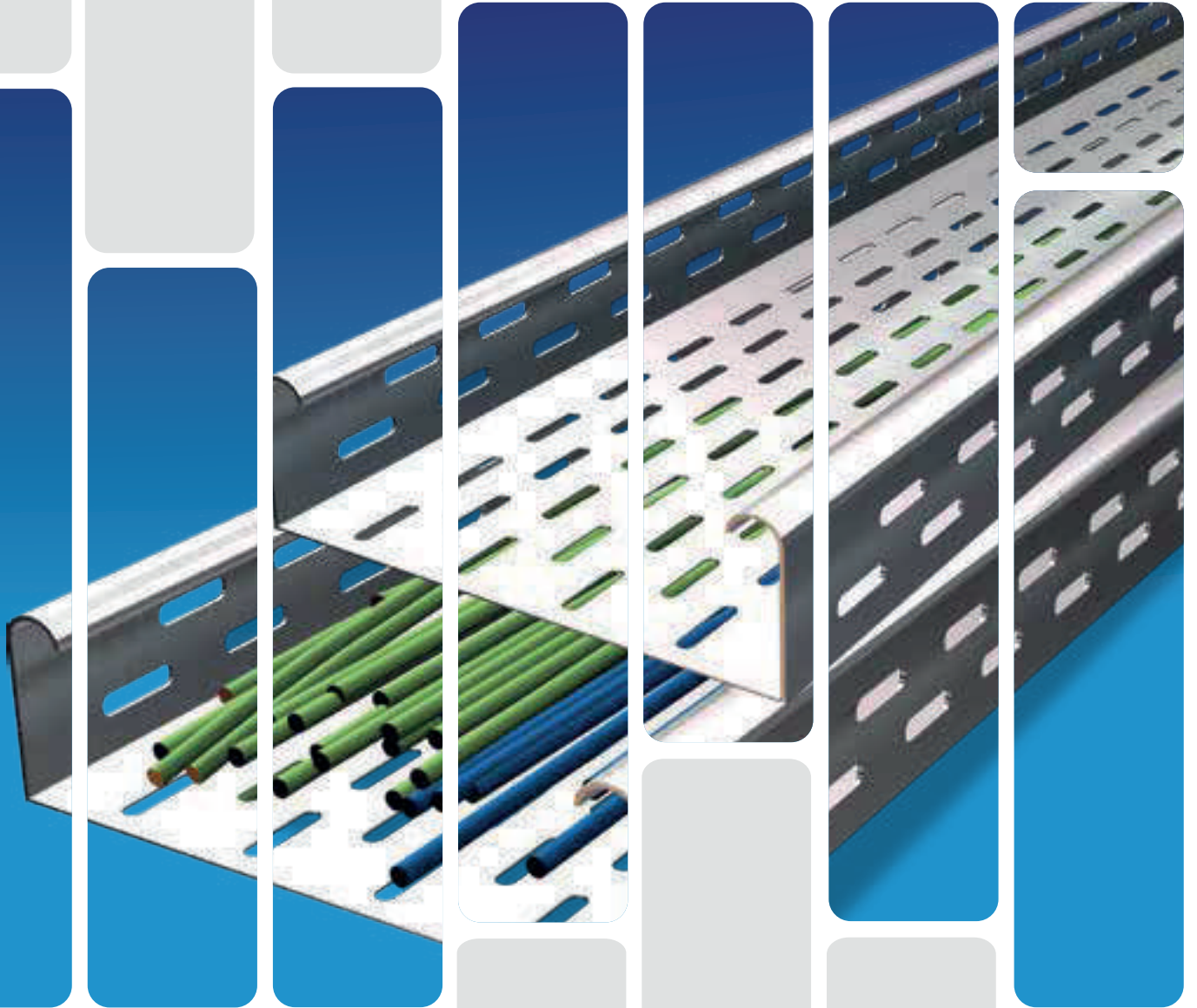

CABLE MANAGEMENT SYSTEMS
CABLE TRAYS & ACCESSORIES



KINETIC ENGINEERING
Exploring New Possibilities

Cable Trays & Accessories

Index

About Kinetic	3
Cable Management System	4
Product Range	5
Cable Tray System	7
Installation Services	8
How to Order	9
Contact Information	10



INTRODUCTION

Kinetic is a leading manufacturer and fabricator of light steel construction products in the region, servicing the construction sector through its state of the art facilities which are spread all over the Pakistan. Products of Kinetic are manufactured from quality raw material according to the relevant international standards to meet all kinds of construction projects requirements, such as MEP, automation & waste management systems.

Commitment to Quality

Our commitment to quality is clearly revealed in the way we do our business; our processes, our close interaction with our clients as well as the strict product inspection procedures. To achieve this, we have implemented quality systems & processes that are continually being improved to satisfy our customer's needs.

Product Development

Product development process is substantial to the success of our business. We leverage all resources to provide up-to-date reliable products, environmentally friendly, durable to withstand the toughest weather conditions. Our engineers are constantly testing the products, seeking to present a combination of performance and quality across all our product ranges.

For more information, please visit:

www.kineticengineering.com.pk

Our Design Office

"Our Design Office" is the core hub of creativity and innovation at Kinetic Engineering. It is the dedicated department where our team of skilled engineers, designers, and experts come together to provide exceptional design solutions and services for our clients. Within "Our Design Office," we offer a comprehensive range of services that cater to various engineering needs. Our services include:

■ Product Design and Development:

Our team excels in designing and developing innovative and functional engineering products. From conceptualization to final production, we ensure that our designs meet the highest standards of quality and performance.

■ 2D and 3D Design:

Using state-of-the-art software and tools, we create detailed 2D and 3D designs that provide a clear visualization of the product, its components, and its functionality. These designs serve as a foundation for further development and manufacturing processes.

■ Customization:

We understand that every client has unique requirements. Our design office specializes in providing tailored engineering solutions that address specific challenges and meet individual client needs. We work closely with our clients to understand their goals, preferences, and constraints to deliver personalized design solutions.

■ Technical Support:

We provide comprehensive technical support throughout the design and development process. Our team of experts is readily available to answer queries, provide guidance, and offer solutions to any design-related challenges that may arise.

CABLE TRAY SYSTEM

Kinetic's range of Cable Tray Systems has been developed to suit the demands of an ever-changing market. State of the art technology has developed our production facility which is able to respond quickly to the demands of the market, making Unitrunk one of the most advanced companies in the industry.

Kinetic Cable Tray Systems consist of light, medium and heavy duty pattern with standard perforations. The requirements of a cable tray finish can vary, depending upon the situation, from being purely cosmetic to being capable of providing protection in the most corrosive environments.



Kinetic cable trays are supplied as complete kits with all necessary fixings. Each fixing kit comprises of a component lid, cover fixing bracket, a corrosion resistant spire clip, screws and nut.

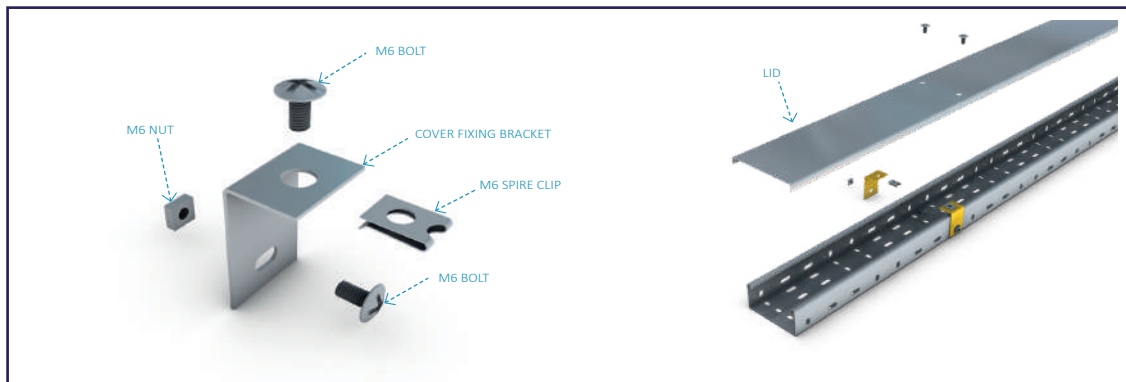

TYPES OF SIDE HEIGHTS



TYPES OF PERFORATION

Staggered

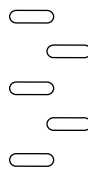

Serial

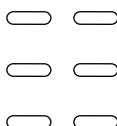

DIMENSIONS

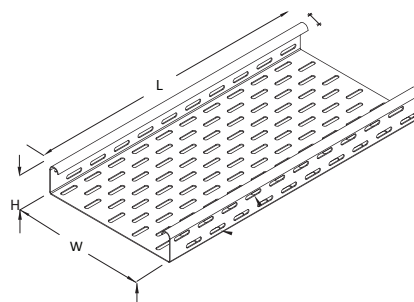

MATERIAL

- MS** Mild Steel - Plain
- MS** Mild Steel - Galvanized
- SS** Stainless Steel
- AL** Aluminum

FINISHES

- HDG** Hot-DIP Galvanization.
- ZP** Zinc Electroplating.
- PC** Powder Coating.

Products Range

Ladder (Cable Ladder)

Our Cable Ladder systems provide robust support and efficient cable management solutions. With their ladder-like structure, they offer excellent strength and durability. The open rungs allow for easy cable entry and exit, facilitating hassle-free installation and maintenance.

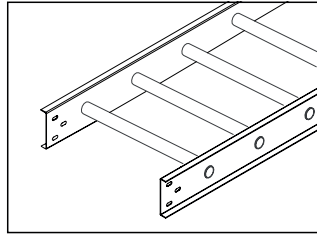

Swaged Rounded Tubular

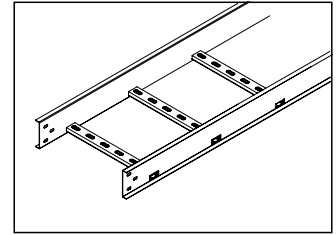

Welded C-Channel

Perforated Cable Tray (Cable Trays)

Perforated Cable Trays are designed to offer optimal cable ventilation and support. The carefully placed perforations on the tray allow for efficient heat dissipation and airflow, preventing cable overheating and minimizing the risk of system failure. These trays provide excellent cable organization and management, ensuring a neat and tidy installation.

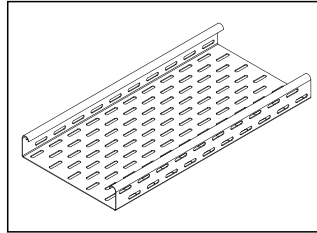

Perforated Cable Tray

Wire Mesh (Basket Tray)

Our Wire Mesh Cable Trays, also known as Basket Trays, provide versatile and flexible cable management solutions. The interwoven wire mesh construction offers excellent cable support while allowing for maximum airflow.

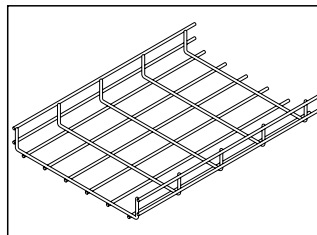

Wire Mesh

Solid (Cable Trunking)

Our Cable Trunking systems are available in different sizes and configurations, making them suitable for a wide range of applications, including commercial buildings, industrial facilities, and residential complexes.

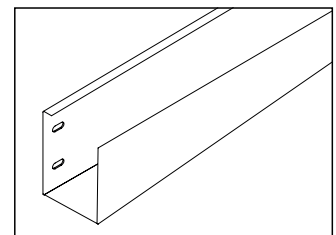
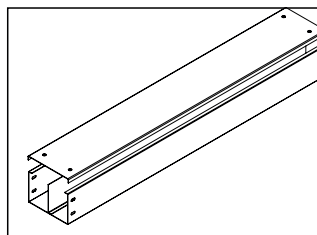

Cable Trunking

Cable tray accessories and fittings

Our comprehensive range of cable tray accessories and fittings ensures a complete and efficient cable management system. From connectors and couplers to supports and brackets, we offer high-quality accessories that seamlessly integrate with our cable trays. These accessories provide secure connections, proper support, and enhance the overall functionality of the cable tray installation.

PERFORATED AND CLOSED STRAIGHT ELEMENTS



Perforated straight elements

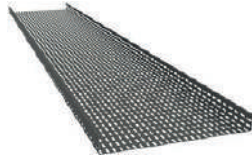

Perforated straight elements with bordered flange



Closed straight elements with bordered flange



Covers and fixing clip

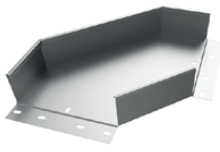

Plane elbows

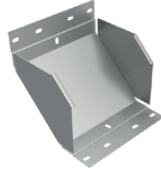

Inside, outside and adjustable elbows

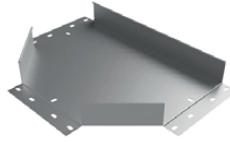

T derivations

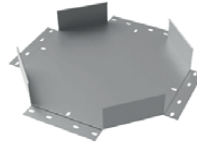

Cross elements

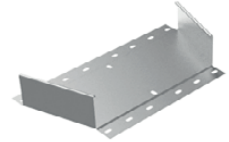

Reductions

CABLE LADDERS



Closed cable ladders



Perforated cable ladders



Covers and fixing clip



Plane elbows



Inside, outside and adjustable elbows



T derivations and cross elements



Reductions and fixingplates

SUPPORTS AND JOINTS

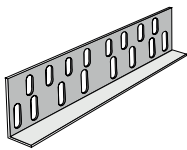

Joints

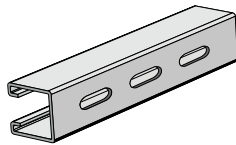

Profile

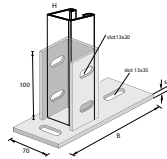

Supports

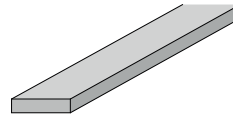

Bars and beams



Wire mesh cable tray

Cable Tray Systems

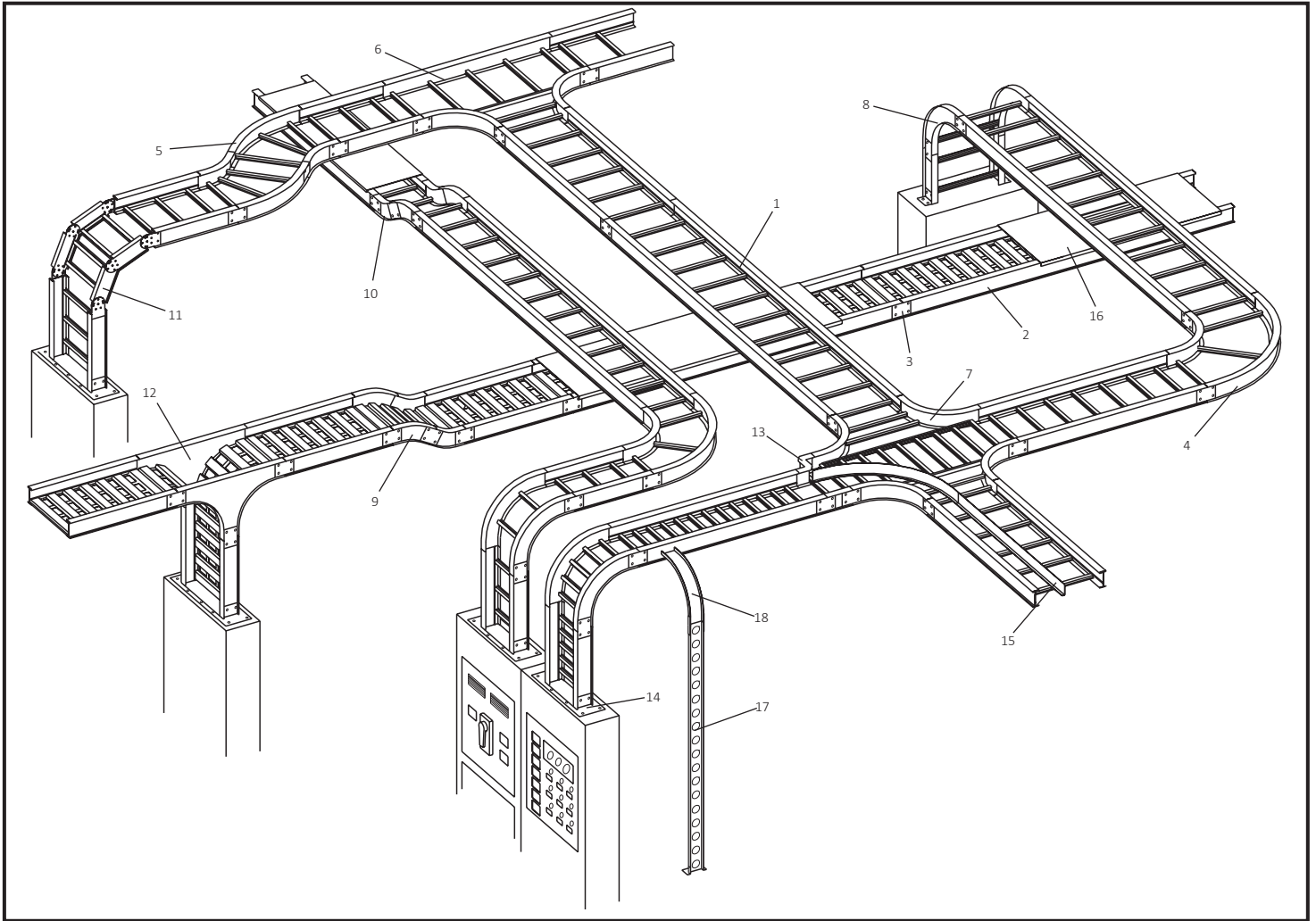

Nomenclature

- | | |
|---|---|
| 1 Ladder Type Cable Tray | 10 30° Vertical Inside Bend, Ladder Type Cable Tray |
| 2 Ventilated Trough | 11 Vertical Bend Segment (VBS) |
| 3 Straight Splice Plate | 12 Vertical Tee Down, Ventilated Trough |
| 4 90° Horizontal Bend, Ladder Type Cable Tray | 13 Left Hand Reducer, Ladder Type Cable Tray |
| 5 45° Horizontal Bend, Ladder Type Cable Tray | 14 Frame Type Box Connector |
| 6 Horizontal Tee, Ladder Type Cable Tray | 15 Barrier Strip Straight Section |
| 7 Horizontal Cross, Ladder Type Cable Tray | 16 Solid Flanged Tray Cover |
| 8 90° Vertical Outside Bend, Ladder Type Cable Tray | 17 Ventilated Channel Straight Section |
| 9 45° Vertical Outside Bend, Ventilated Type Cable Tray | 18 Channel Cable Tray, 90° Vertical Outside Bend |

INSTALLATION SERVICES

At Kinetic Engineering, we not only provide top-of-the-line cable trays but also offer professional installation services to ensure a seamless and efficient cable management system. Our installation services are conducted by a team of experienced technicians who possess the necessary expertise and skills to handle complex installations with precision and attention to detail. Here are the detailed features and benefits of our cable tray installation service:



Our installation service for cable trays goes beyond the basics to provide you with a comprehensive and hassle-free experience. We understand that a properly installed cable tray system is essential for efficient cable management and the overall performance of your electrical infrastructure. Here are the detailed features and benefits of our cable tray installation service:

1. Expertise of Experienced Technicians:
2. Thorough Assessment and Planning:
3. Customized Solutions:
4. Efficient Execution:
5. Meticulous Mounting and Secure Connection:
6. Cable Routing and Organization:
7. Compliance and Safety:
8. Testing and Performance Verification:
9. Reliable Support and Maintenance:

By choosing our cable tray installation service, you can expect a seamless, efficient, and professional experience. We prioritize quality, safety, and customer satisfaction to deliver a reliable and durable cable management solution that optimizes the performance of your electrical systems.

Factory:

6F Mehran Town Sector, Korangi Area, Karachi

Head Office:

Office # 302, 3rd Floor, SP Chamber, Near Habib Bank Flyover,
S.I.T.E Area, Karachi.

Contact No: 021-32551193

